



Elektrometal Energetyka SA®



e²TANGO® -450 Bay Controller





e²ALPHA

Elektrometal Energetyka SA

e²TANGO 450

Elektrometal Energetyka SA

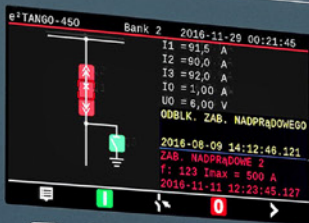

Zad U>

Zad I>INV

Rej. zakł. F1

Symulacja pom. F2

- AL
- AW
- UP
- Zad I>>
- Zad I>-1
- Zad I0>
- Zad I0>d1
- Z...

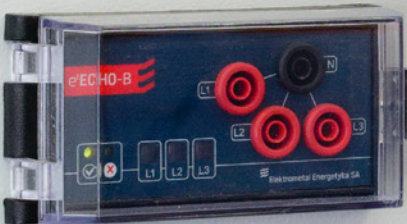

NAPIĘCIE NA KABLU



STEROWANIE CZŁONEM RUCHOMYM



STEROWANIE WYŁĄCZNIKIEM



STEROWANIE UZIEMNIKIEM



OŚWIETLENIE POŁA



WE CREATE IDEAS WITH POWER!

e²TANGO-450 protection relays are the solution developed by ELEKTROMETAL ENERGETYKA SA R&D department consisting of engineers with extensive know-how and many years of experience in the industry. Employed solutions and concepts answer challenges which our customer face in their day-to-day operations. These challenges were our key inspiration during design work. This allowed us to develop this compact, user-friendly and intuitive protection relay, which does not require initial, advanced training for operating personnel. e²TANGO-450 are the perfect addition to e²TANGO protection devices line-up.

We have developed a technologically advanced device, universal in its programming and hardware functionality for operating protection relays, control, measurement, data logging and monitoring of MV switchgear bays.

The protection relays stands out in more than one way but easy and convenient operation is one of its more prominent features. We wanted to develop a uniquely user-friendly and intuitive device capable of operating in SMART GRIDS. e²TANGO-450 versatility and compact size allows easy adaptation to specific requirements of users and protected loads. We fully realize the importance of safety in power engineering, this is why this was one of the key aspects we focused on. All our products including e²TANGO protection devices are fully type-tested and certified by most demanding laboratories.

e²TANGO-450 are the unique protection relays. This knowledge gives us confidence when recommending this device to our customers.



Dariusz Rybak

Main Designer

Elektrometal Energetyka SA



APPLICATION

e²TANGO-450 protection relays have complete set of protection functions and station automation schemes making them ideal for any type of bay irrespective of its application and operational characteristics: such as incoming bay, line incoming-outgoing bay, transformer bay, measuring bay, coupling bay, capacitor bank bay for MV grids. In particular, our devices are dedicated to renewable energy power plants such as wind and solar farms.



wind and solar power plants

- undervoltage and overvoltage protection
- frequency protection
- automatic load shedding
- automatic transfer switch

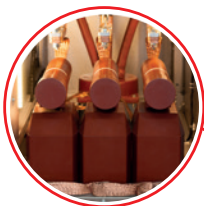

measurement bay

- undervoltage and overvoltage protection
- zero-sequence component overvoltage type protection
- automatic load shedding



motor bays

- thermal model
- PT100/PT1000 sensors
- start-up time protection



transformer bay

- thermal protection
- under-/overvoltage protection
- interoperation with flux-gas protections
- block on 2nd harmonic detection



line bays

- ground-fault protection
- admittance based protection
- automatic load shedding



capacitor bank bays

- capacitor bank internal current
- automatic inclusion of capacitor bank



incoming bay

- ATS interoperation system
- automatic bus-bar protection
- automatic breaker failure protection

PROTECTION RELAY ADVANTAGES



quick device start

basic configuration assistant, comprehensive database of ready synoptic diagrams and protection sets



service access

remote and local readout of diagnostic data with possibility of sending it to manufacturer service department



high resistance to interference

up to 100% higher than required by the standard



trouble-free battery change

possible to change battery without turning off the feeder

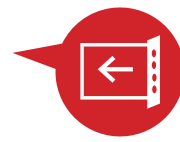

availability of expansion cards

input and output cards, communication cards

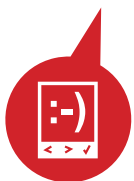

intuitive interface

legible menus, consistent across all eTANGO protection systems and relays



may be used without training

handy help system

fully configurable text interface

up to five configurable screens, widget database

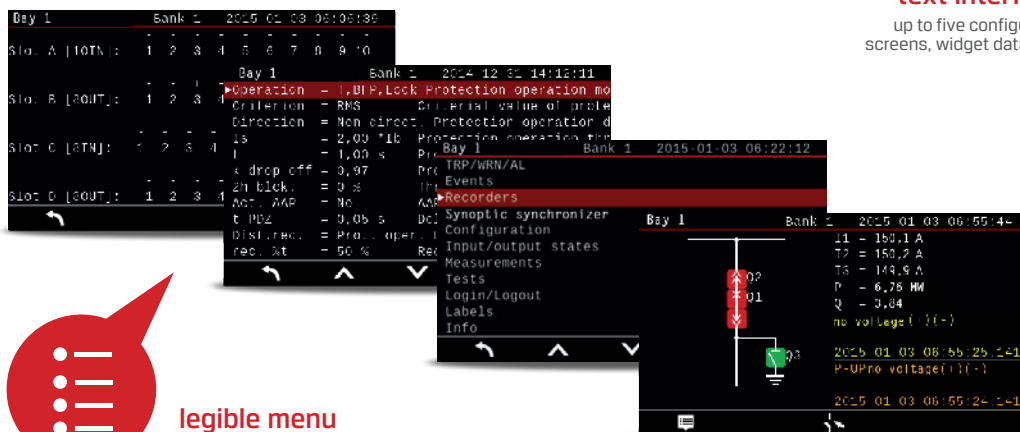

legible menu

consistent across eTANGO protection systems and relays

DESIGN

e²TANGO -450 protection relay has a 4.3" colour graphical display and a keyboard with 5 context-sensitive buttons for easy operation. There are LEDs on the front panel providing visual indication of device statuses.

e²TANGO-450 have two additional function buttons F1 and F2 with dedicated two-colour LEDs which may be customised. Label pockets are provided on the relay front panel for function buttons and LED indicator labels.

INTERFACE AND OPERATION	
Display	4,3"
Display resolution	480x272px
Colour display	•
Operating buttons (number)	5
Control buttons (I,0,<->)	4
Programmable function keys with LED	2
LED (including 3 colour)	13 (3)
Replaceable labels	•
DESIGN AND STANDARD EQUIPMENT	
Current input no.****	4
Voltage input no. 1****	1(4)
Max. switching device no.*	6
Ethernet input	1
miniUSB	1

AVAILABLE EXPANSION CARDS**	
Binary input cards	o (39)
Relay output cards	o (30)
Temperature input cards ***	o (6)
Flash sensor input cards ***	o (6)
4-20 mA analogue input cards ***	o (4)
0-10 V analogue input cards ***	o (4)
4-20 mA analogue output cards ***	o (4)
0-10 V analogue output cards ***	o (4)
Voltage measurement cards	o (3)
Communication cards	o (1)
DATA RECORDERS	
Event recorder	1100
Disturbance recorder	30s / 1.6kHz/s
OTHER	
Widgets	•
Synoptic diagram database	•
No. of configurable screens	5

•/o - standard/option

* - requires appropriate number of expansion cards

** - maximum 4 slots available, card 603I inserted in slot A; input/output number provided in brackets relates to the rest of slots for 12IN or 80UT cards

*** - only 1 module may be installed

**** - available configuration with a card for measuring 3 voltages

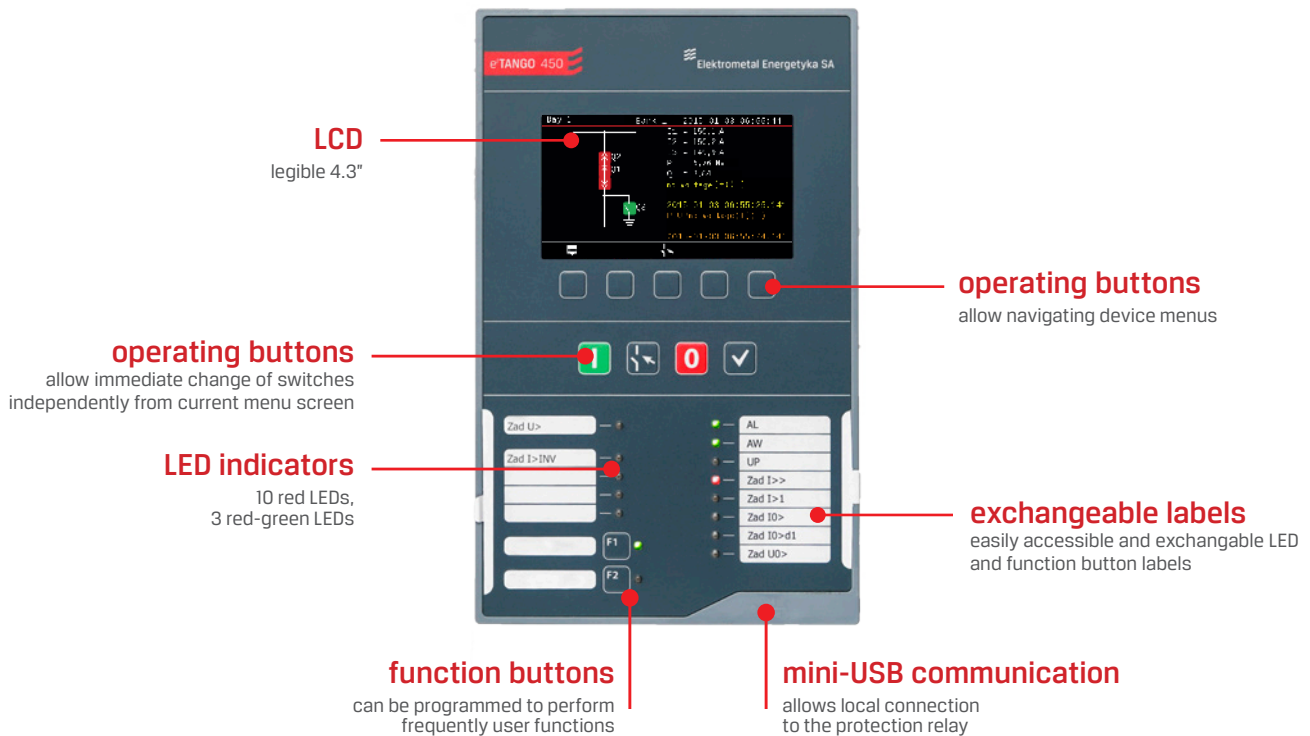

PROTECTION FUNCTIONS

13	Synchronous-Speed
21NY	Admittance directional protection
23/26	Temperature protection (PT100 sensor)
23/26/62	Temperature protection (binary)
27/27P	Undervoltage
27/ARC	Arc protection
32P	Reverse active power protection
37	Undercurrent protection
46	Phase balance or reverse sequence current protection
48	Incomplete Sequence
49	Thermal protection
50/50N/50Ns/50G	Overcurrent / ground overcurrent protection
50HS/SOTF	Switch on to fault protection
50LR/51LR	Locked rotor
50NC/51NC	Capacitor bank overcurrent
51/51N	Inverse overcurrent protection

51/51N/51Ns/51G	Time overcurrent / ground time overcurrent protection
51N/59N	Ground time overcurrent with voltage interlock
51Ns/51G	Inverse ground overcurrent protection
59/59P/59_1/59_2	Overvoltage
59N	Ground overvoltage
62	External binary protection
66	Notching or Jogging Device / Maximum Starting Rate / Starts Per Hour / Time Between Starts
67/67N/67Ns/67G	Directional overcurrent / ground directional overcurrent protection
74TCS	Trip, close coil supervision
80	Flux-gas
810	Under-frequency protection
81R	Rate of change of frequency
81U	Over-frequency protection

AUTOMATIC SYSTEMS

- (41N) Active component forcing
- (50/68) Busbar protection
- (50BF) Breaker failure protection
- (79) Auto reclose
- (79VF) Automatic "island" reclose function with option of locking after multiple power-up
- (81U/810) Automatic load shedding
- (90C) Capacitor bank switching
- (CLP) Cold load pickup

EXPANSION CARDS

BASIC CARDS

- power supply unit
- central processor unit

FUNCTION CARDS

- 6 relay outputs + 3 binary inputs
- 8 relay outputs
- 8 relay inputs
- 12 binary inputs
- 8 binary inputs 24 V
- 12 binary inputs 24 V

OTHER

- voltage measurement card (TU)
- current measurement card (TR)

ANALOGUE CARDS

- 4 analogue inputs 0-10 V
- 4 analogue inputs 4-20 mA
- 4 analogue outputs 0-10 V
- 4 analogue outputs 4-20 mA

TEMPERATURE SENSORS CARDS

- 6 PT100 inputs
- 6 PT1000 inputs
- 6 arc detector inputs with communication CANbus + 3 standard sensors (ARC)

COMMUNICATION PORTS AND PROTOCOLS

- Ethernet
- Multi-mode glass optical fibre - OPTOMM
- Plastic optical fibre OPTOP
- RS485
- CANbus 2x
- USB 2.0
- Modbus RTU / TCP
- IEC 60870-5-103
- DNP 3.0
- Profibus
- CANbus / PPM 2
- IEC 60870-5-104

DIMENSIONS AND MOUNTING METHODS

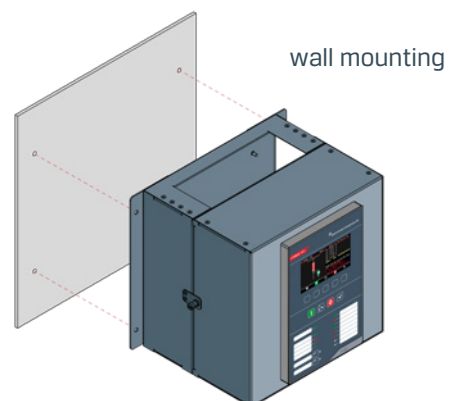
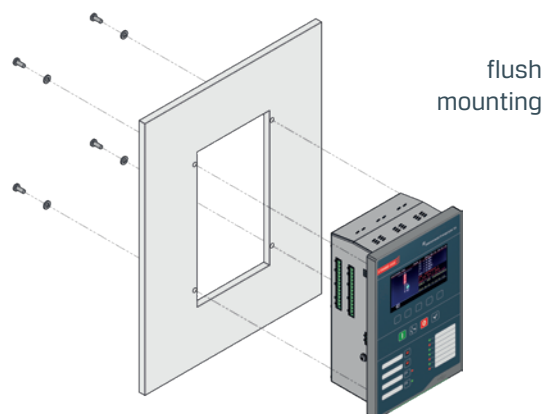
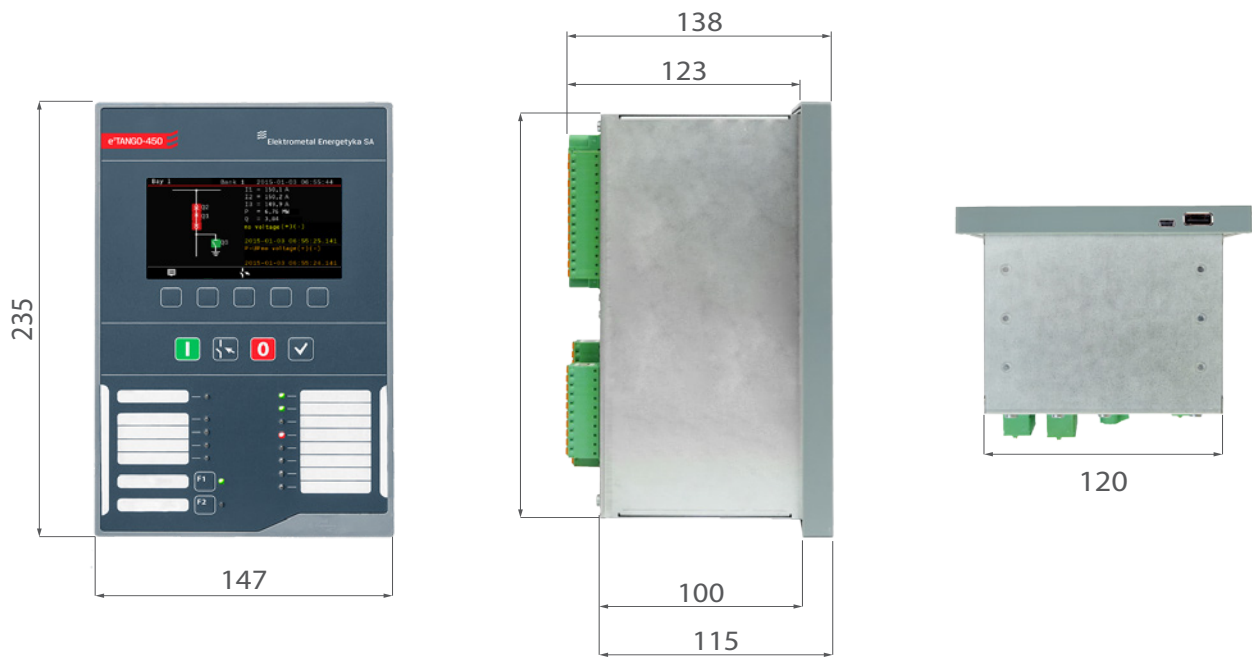

TECHNICAL PARAMETERS e²TANGO-450

AUXILIARY POWER SUPPLY	
VDC VAC	110 V, 220 V (80-300 V) 230 V (88-265 V)
Maximum power consumption Option	10 W (VA) 24 V, 110 V DC (19-132 V DC)
CURRENT MEASUREMENT CIRCUITS	
Rated current	5 A / 1 A (configurable)
Rated frequency	50 Hz
Phase current measurement range	0.05-150A Others for request
I ₀ current measurement range	0,005-1 A/0,1-10 A
VOLTAGE MEASUREMENT CIRCUITS	
Rated voltage	57.7/100/230 V
Voltage measurement range for transformers	3-280 V
U ₀ measurment circuit	
Transformer measurment range	3-280 V
BASIC PROTECTION PARAMETERS	
Over protection relay resetting ratio	Configurable
Under protection relay resetting ratio	Configurable
Device operate time	typically - 35 ms
MEASUREMENT ACCURACY	
I ₁ , I ₂ , I ₃ (0.1-30 I _n / 0.05-0.1 I _n)	2% / 2.5%
U ₀ measured or calculated (5-280 V)	2%
I ₀ measured (0.005-1 A/0.1-10 A) calculated (0.1-30 I _n)	2% 3%
U ₁ , U ₂ , U ₃ (5-280 V)	2%
φ 1, φ2, φ3, φ0 (U>5V, 0.1In<K30 In)	2°
f (U>0.5Un)	10 mHz

BINARY INPUT CIRCUITS	
603I card	24-230 V AC/ DC
8IN, 12IN cards	110-230 V AC/ DC
8IN24, 12IN24 cards	24 V DC (19-58 V AC/DC)
Others for request	
Maximum power consumption: 220 V DC, 230 V AC	2 mA, 15 mA
RELAY OUTPUT CIRCUITS (603I CARD)	
Circuit opening at 220 V DC	5A
Circuit opening at 220 V DC (L/R = 0)	0.4A
Circuit opening at 220 V DC (L/R = 40 ms)	0.3A
RELAY OUTPUT CIRCUITS (OTHERS)	
Circuit opening at 220 V DC	5A
Circuit opening at 220 V DC (L/R = 40 ms)	0.1A
Circuit opening at 230 V AC (cos = 0.4)	2.0A
Allowable voltage at open contacts at 220 V DC	250 V AC/440 V DC
ENVIRONMENTAL CONDITIONS	
Operating temperature	-25°C ... +55°C
Operating temperature	-25 °C ... +70 °C
Relative humidity	5 to 95%, non-condensing
Vibration and mechanical shock resistance	Class 1 acc. IEC 60255-21
Electromagnetic disturbances	Class B acc. IEC 60255-26
SAFETY	
Insulation electric strength	2 kV/50 Hz/60 s acc. IEC 60255-27
DIMENSIONS	
Weight (central processing unit/panel)	1 kg
Dimensions (W x D x H mm)	147x115x235
Protection rating (at terminal side)	IP3X
Protection rating (at front panel side)	IP4X / (IP54 optional)

e²TANGO-STUDIO SOFTWARE

e²TANGO-Studio engineering software allows operation of e²TANGO-450 protection relay and also panel configuration. This software provides comprehensive functionality, which together with visual widget configuration is a perfect aid in daily work by enabling creation of projects for multiple devices, bays, switchgears or stations.



quick configuration assistant

helps first time users of the software and facilitates regular use



advanced design functions

ability to prepare device configuration for an entire switchgear on a PC and distribute it using USB



on-line preview

real-time preview of measurement input/output status displaying actual LCD screen content

display conformity

preview of the actual panel screen

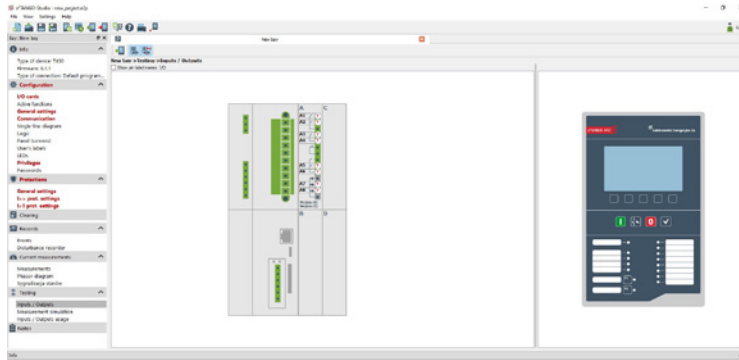

visual characteristic modification

graphical and classic protection setpoint configuration

easy setpoint and selectivity verification

displaying setpoints of all related overcurrent protection functions on one chart



full status preview

access to all internal device and protection function statuses

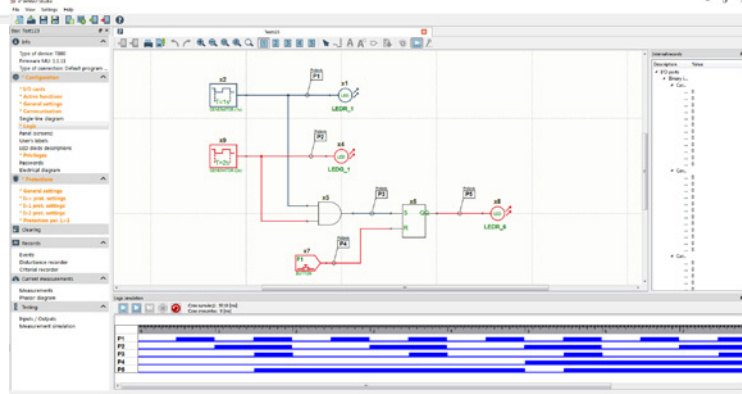

possible expansion using plug-ins



logic simulator

possibility to simulate whole logic without connection with device

logic clarity

possibility to split logic in blocks and sheets



ultra-fast design of custom screens

drag&drop element placement



support for sophisticated logical dependencies

up to 340 logic gates / elements

„miniSCADA” FUNCTIONALITY

e2TANGO-Studio has possibility to expand with "miniSCADA" functionality that lets you visualise state of switchgear and allows to manipulate switches, alarms and events preview and online access to measured parameters of protection relay (e.g. current, voltage, power, energy) installed in switchgear. Functionality was designed to share engineering link (one communication port) to protection relays, which gives possibilities for costs optimization by wiring and infrastructure simplifying.

"miniSCADA" plug-in is optional as additional license.



intuitive configuration of screens
possible to use widgets



data transmission using available communication ports
RS485, OPTO, Ethernet and others

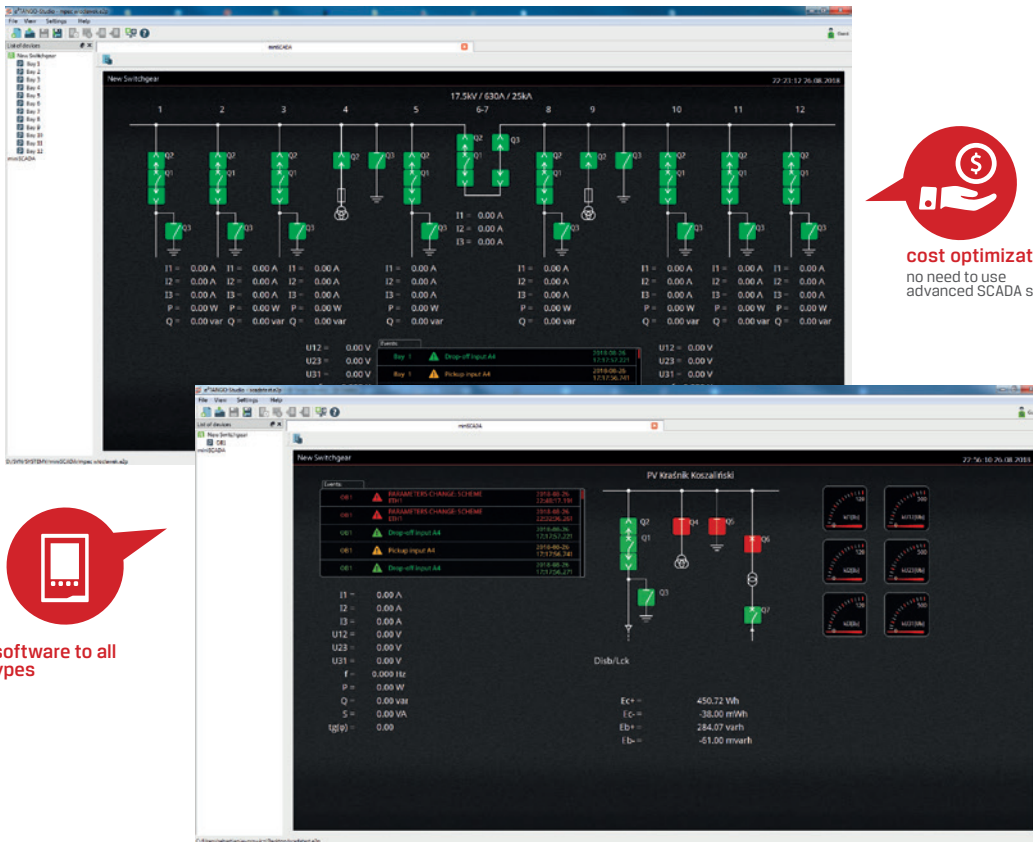

cost optimization
no need to use advanced SCADA systems



universal software to all e2TANGO types



possible to work in any operating system



access from mobile devices

ADVANCED LOGIC EDITOR AND SIMULATOR

e2TANGO-Studio provides an advanced and comprehensive logic editor which allows running logic simulation. It gives preview of logic states when used with a device aiding project design, as well as commissioning and servicing of switching stations. The editor allows creating custom logic adapted to customer infrastructure requirements.

STANDARDS

PN-EN 60255-1	Measuring Relays And Protection Equipment. Part 1: Common Requirements
PN-EN 60255-26	Measuring Relays And Protection Equipment. Part 26: Electromagnetic Compatibility Requirements
PN-EN 60255-27	Measuring Relays And Protection Equipment. Part 27: Product Safety Requirements

CERTIFICATES AND AWARDS



Conformity certificate IEN
no DZC.521.59.2.2023



Masovian Quality Award



The Minister of Energy Cup
ENERGETAB 2018 Fairs



Forbes Diamonds 2023

ELEKTROMETAL ENERGETYKA SA QUALITY

Implemented Integrated Management System according to:

- PN-EN ISO 9001 Quality management systems
- PN-EN ISO 14001 Environmental management systems
- PN-EN ISO 45001 Health and Safety Management System

ORDER FORM

To order e²TANGO- 450 protection relay fill in this part of the form following FORM INSTRUCTIONS provided on the next page.

STEP 1

① version 450

② type S (standard, 4I+1U)

③ binary input voltage UNI (110/230 V AC/DC) 24 V (24/110 V DC)

Ethernet (standard equipment in each central unit)

④ COM1 x-none RS485 CAN×2 OPTOMM OPTOP Profibus others

⑤ mounting Z - flush mounting N - wall mounting

⑥ protection rating IP IP4X IP54

STEP 2

Card name	Kod	Slot				
		A	B	C	D	TU
Ethernet	-	standard for the device				
6 relay outputs + 3 binary inputs	603I		X			
8 binary inputs	8IN			<input checked="" type="checkbox"/>	<input type="checkbox"/>	
8 binary inputs 24 V	8IN24		<input type="checkbox"/>	<input type="checkbox"/>	<input type="checkbox"/>	
12 binary inputs	12IN		<input type="checkbox"/>	<input type="checkbox"/>	<input type="checkbox"/>	
12 binary inputs 24 V	12IN24		<input type="checkbox"/>	<input type="checkbox"/>	<input type="checkbox"/>	
8 relay outputs	8OUT		<input type="checkbox"/>	<input type="checkbox"/>	<input type="checkbox"/>	
4 0-10 V analogue inputs	AI10		<input type="checkbox"/>	<input type="checkbox"/>	<input type="checkbox"/>	
4 4-20 mA analogue inputs	AI20		<input type="checkbox"/>	<input type="checkbox"/>	<input type="checkbox"/>	
4 0-10 V analogue outputs	A010		<input type="checkbox"/>	<input type="checkbox"/>	<input type="checkbox"/>	
4 4-20 mA analogue outputs	A020		<input type="checkbox"/>	<input type="checkbox"/>	<input type="checkbox"/>	
6 temperature inputs PT100	PT1		<input type="checkbox"/>	<input type="checkbox"/>	<input type="checkbox"/>	
6 temperature inputs PT1000	PT10		<input type="checkbox"/>	<input type="checkbox"/>	<input type="checkbox"/>	
6 arc detector inputs with CANbus communication + 3 standard detectors	ARC		<input type="checkbox"/>	<input type="checkbox"/>	<input type="checkbox"/>	
voltage measurement	TU					<input type="checkbox"/>

additional arc detectors (max. 3 pcs.) only if ARC card is ordered.

additional requirements:

STEP 3

Your code:

See FORM INSTRUCTIONS on the following page

e²TANGO ① ② ③ ④ ⑤ ⑥ ⑦ A B C D TU

FORM INSTRUCTIONS

STEP 1

The table contains basic technical specification of e²TANGO-450 protection relay. In each item 1 through 8 choose only ONE element. If you choose "other", in STEP 3 fill in the requested value in a corresponding field.

Step 1 instructions.

- - recommended basic configuration
- OPTOMM - multi-mode optic fibre
- OPTOP - plastic fibre optic

KROK 2

The table contains a list of available expansion cards and their possible installation locations in e²TANGO-450 protection relay

If no check mark field is available the card cannot be installed in a given location. Select desired cards from the list and put an "X" mark next to slot where the card is to be installed.

Step 2 instructions.

- - recommended basic configuration
- max. 1 AI10 card or 1 AI20 card
- max. 1 A010 card or 1 A020 card
- max. 1 PT1 card or 1 PT10 card

Any additional requirements should be described in designated fields.

View of the central unit

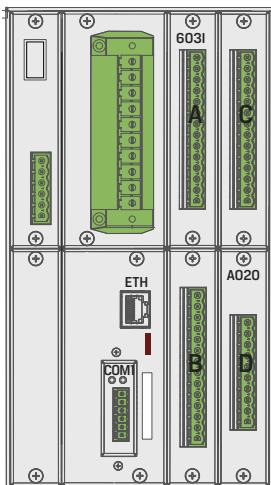

STEP 3

e²TANGO-250, -450 protection system parameters selected above should be filled-in in corresponding locations. Send thus created e²TANGO code along with other requirements or a scanned form page and order form to: eaz@elektrometal-energetyka.pl

Sample e²TANGO-450 protection configuration:

① e ² TANGO-450	⑦ IP4X
② Standard	A slot A: 603I card
③ Universal 230 / 110 AC / DC	B slot B: 80UT card
④ RS485	C slot C: 80UT card
⑤ Flush mounting	D slot D: A020 card
	TU slot TU: TU card

Sample e²TANGO-450 protection configuration:

e²TANGO 450 S UNI RS485 Z IP4X 603I 80UT 80UT A020 TU

ELEKTROMETAL ENERGETYKA SA

67 Działkowa Street

02-234 Warsaw, Poland

phone (+48) 22 350 75 50

fax (+48) 22 350 75 51

export@elektrometal-energetyka.pl

www.elektrometal-energetyka.pl