



Elektrometal Energetyka SA



HV protection unit e²TANGO-2000-TRR[®] (Transformer differential protection)



Elektrometal Energetyka SA **FR1 TRANSFORMATOR 110/15 kV TR1**

eTANGO 3300 Elektrometal Energetyka SA

Panel 1: K01 (13.07.16 11:53:30.00)

110 kV

U₁ = 115.30 V
 I₁ = 115.00 V
 I₂ = 5.31 A

AMN = NADZIORY

Buttons: P1, P2, P3, P4

K01
AUTOMATYCZNA
REG. NAPIĘC.
TRANSFORMATORA

eTANGO 3300 Elektrometal Energetyka SA

Panel 2: K02 (13.07.16 11:53:30.00)

110 kV

U₁ = 115.30 V
 I₁ = 115.00 V
 I₂ = 5.31 A

Buttons: P1, P2, P3, P4

K02
STEROWANIE
PŁYWKI

eTANGO 3300 Elektrometal Energetyka SA

Panel 3: K03 (13.07.16 11:53:30.00)

110 kV

I₁ = 115.30 V
 I₂ = 115.00 V
 I₃ = 5.31 A

Buttons: P1, P2, P3, P4

K03
ZABIEGACZKA
REGULACJI
TRANSFORMATORA

eTANGO 200 Elektrometal Energetyka SA

TR 006

Buttons: P1, P2

K04
AUTOMATYCZNE
ZABIEGACZKI
NADZIORY

We create ideas with power!

The family of the e²TANGO-2000-series HV protection relays has been developed by our R&D team consisting of engineers with extensive practical knowledge and many years of experience in the industry. The idea behind creating a high-voltage protection automation platform was to provide clients with operational surety of hardware, software and algorithms.

The e²TANGO-50, e²TANGO-100, e²TANGO-200, e²TANGO-400, e²TANGO-600, e²TANGO-800, e²TANGO-1000, e²TANGO-1200 protection relays and bay controllers for MV have been installed in thousands of facilities across the country and Europe. The hardware platform is based on the same central unit as for the e²TANGO series, of course, with the same configuration of processors, memory cards, inputs/outputs, etc. This makes us absolutely convinced that a few years of trouble-free operation of the e²TANGO series hardware gives security for applications in sensitive areas of HV stations and switchgears.

The e²TANGO-2000 software was developed on the basis of proven versions for MV controllers, while the algorithms of protections operation were developed in cooperation with the Institute of Power Engineering in Warsaw. Thanks to this, the user can be sure that the applied solutions have been tested over the last few decades and work reliably in many HV facilities in Poland and Europe.

The safety of the HV protection relays' users and operated power facilities was our priority when creating e²TANGO-2000. Therefore, in addition to the certainty of the hardware and software side, we have performed a full type testing completed with a certificate confirming the workmanship quality of the HV protection relays series.



Dariusz Rybak
Chief Designer of the e²TANGO series
Elektrometal Energetyka SA



APPLICATION OF HV PROTECTIONS

The e²TANGO HV protections portfolio constitutes a wide range of protection automation devices, including overcurrent and earth-fault protections, differential protection of transformer, voltage regulator, and line residual current protection. The e²TANGO-2000 protection units can be used in bays with the various intended use and operating nature, e.g., in HV line bays or HV/MV transformer bays, but also in facilities of distribution, industrial and other power engineering, which have high-voltage (HV) stations.



HV/MV transformer bay

- differential protection
- overcurrent protection
- Buchholz protection



HV choke bay

- differential protection
- overcurrent protection



HV recipients



HV station

HV/MV TRANSFORMER BAY DIAGRAM

A diagram of exemplary HV transformer bay with marked places for installing the e²TANGO-2000 and e²TANGO-200 type protection automation is presented below.

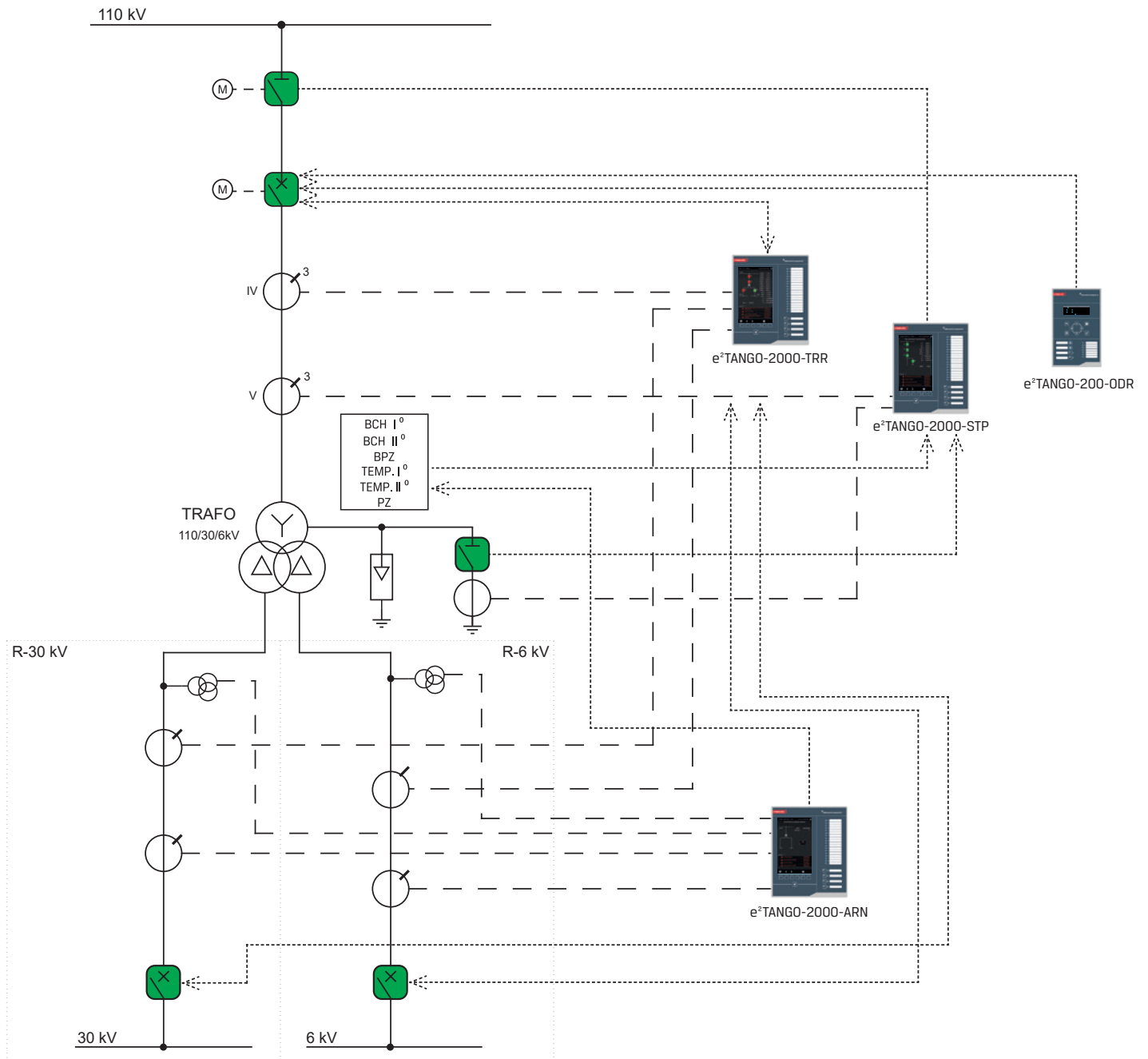

A comprehensive solution for the HV transformer bay, which includes all protection automation elements based on the e²TANGO platform, is demonstrated. The transformer differential protection (TRR), bay controller (STP), and voltage regulator (ARN) are constructed on e²TANGO-2000 base; however, autonomous protections, e.g., -ODR, are designed based on the e²TANGO-200 protection with capacity accumulator.

ADVANTAGES OF HV PROTECTIONS



spinning reserve
restoring the bay to work after a failure within several minutes, possibility to restore all bay data, e.g.: settings, logic, events



remote service access
remote and local readout of diagnostic data with the possibility of sending it to the manufacturer's service



tested algorithms
protection algorithms developed in cooperation with the Institute of Power Engineering



verified hardware base
basing on proven hardware and software of e²TANGO MV controllers

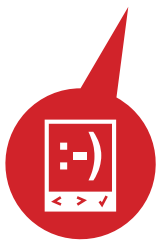
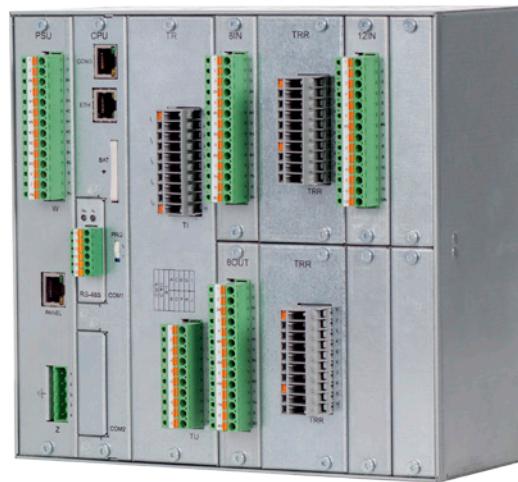

intuitive interface
legible menu layout, pictorialness of captions and markings

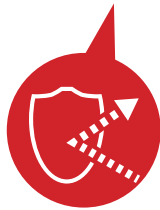

high interference resistance
up to 100% higher than required by the standard

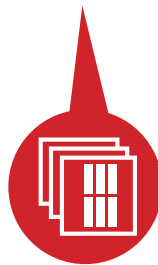

wide range of hardware configurations
10 or 14-slot units are available with surface, flush or mixed installation method



expansion cards' diversity
modular design based on expansion and communication cards, up to 168 inputs and up to 39 outputs



preview of the diagram and logic current status
logic and synoptic diagrams



complete operating manual
quick access to the associated chapters of the technical documentation



legible menu
pictorialness of captions and markings



graphic presentation of parameters
phasors, harmonics content



fully configurable graphic interface
up to five configurable screens, rich widget base



can be operated without the manual
quick-access help

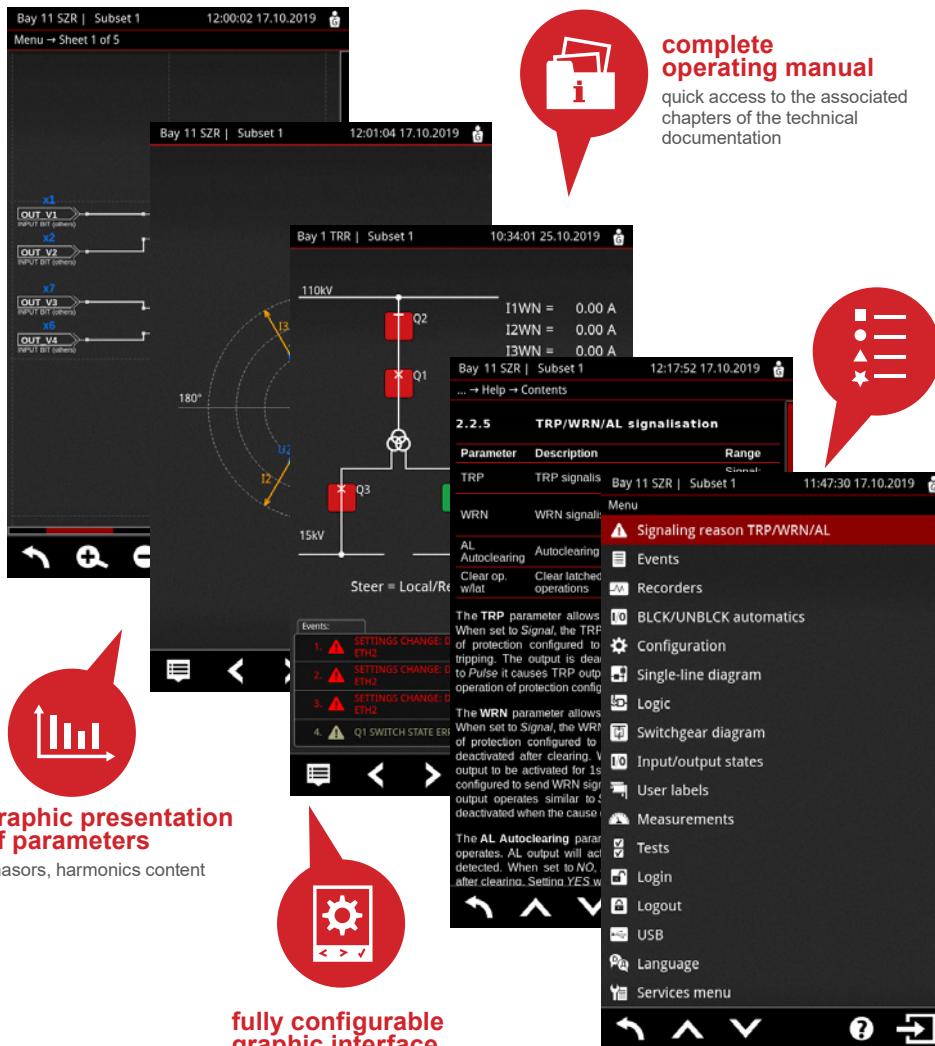

Intuitive and easy-to-use e²TANGO HV protection units are equipped with a fully configurable, clear screen and extensive configuration, registration, and measurement functions. The legibility of indications and signalling, easy access to documentation and instructions, easy verification of logic operation, and graphical verification of protections characteristics or remote service access definitely improve daily work with the device.

DESIGN

The e²TANGO HV protection units consist of two elements: operator panel and central unit. The central unit is made based on expansion cards and comes in three housing versions: J10 (10 cards) and J14 (14 cards) - depending on the complexity of the switchboard bay layout and user needs. The e²TANGO-2000 operator panel has a 7-inch, high-resolution colour screen.

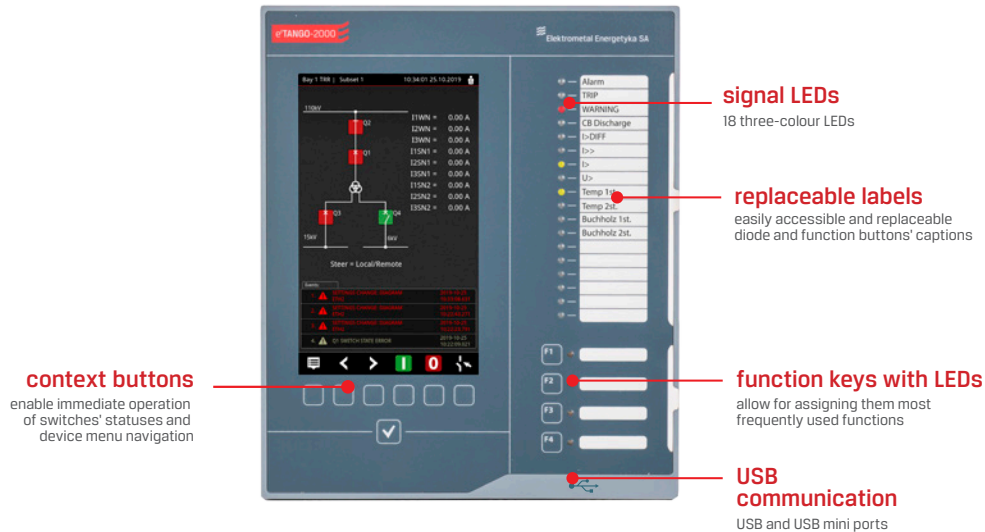

INTERFACE AND OPERATION	
Display	7"
Display resolution	800×480 px
Colour display	•
Touch screen	0
Context buttons (quantity)	-
Control buttons (v)	0
Programmable function keys with LEDs	4
LED	18
Virtual LED (on LCD)	0
Virtual function keys (on LCD)	0
Replaceable labels	•
DESIGN AND EQUIPMENT	
Panel dimensions (external - H×W×D)	252×215×41,5
Mounting opening dimensions in flush version	228×191
External central unit	•
J10 unit	•
<ul style="list-style-type: none"> 10 slots dimensions: 222×234×103 (H×W×D) 	
J14 unit	0
<ul style="list-style-type: none"> 14 slots dimensions: 222×281×103 (H×W×D) 	

STANDARD EQUIPMENT**	
Number of binary inputs (max.*)	28 (168)
Number of binary outputs (max.*)	23 (39)
Max. number of switches	12
Analogue inputs 0-10 V (max.)**	0 (4)
Analogue outputs 4-20 mA (max.)**	0 (4)
Analogue output 0-10 V (max.)**	0 (4)
Temperature inputs (max.)**	0 (12)
Current measuring card for differential protection	0 (2 for TRR)
OTHER	
Widgets	•
Number of configurable screens	5
Logic preview on display	•

•/o - standard / option

* - for the largest unit available and with all slots occupied with one type of card

** - the required number of expansion cards

PROTECTION FUNCTIONS

50/50N short-circuit / instantaneous earth-fault HV, SN1, SN2 sides	51VN zero overcurrent with voltage monitoring / voltage interlock	81R instantaneous change of frequency df/dt and $\Delta f/\Delta t$
51/51N overcurrent / two-stage zero overcurrent delayed	59 two-stage overvoltage (operation selection from phase or line-to-line voltages) HV	30/74 gas protection
50HS shortening of the tripping time in case of activation on short-circuit	27 two-stage undervoltage (with operation selection from phase or line-to-line voltages) HV	49 thermal (binary or sen. PT100)
60/67N overcurrent/two-stage zero overcurrent delayed	81H HV overfrequency	74TCS control of 3 control circuits
49/51 heat overload	81L HV underfrequency	87T two- and three-winding transformer differential protection
59N zero-component overvoltage		

AUTOMATION

- PDZ automation
- LRW automation
- other based on programmable logic

EXPANSION CARDS

PRIMARY CARDS

- power supply or power supply with reinforced contacts (connection ability up to 10 A DC)
- processor

MEASURING CARDS

- standard (5I+4U)
- current measuring card for differential protection

FUNCTION CARDS

- 8 binary inputs
- 12 binary inputs
- 8 relay outputs
- 4 relay outputs with reinforced contacts (connection ability up to 10 A DC)

ANALOGUE CARDS

- 4 analogue inputs 0-10 V
- 4 analogue inputs 4-20 mA
- 4 analogue outputs 0-10 V
- 4 analogue outputs 4-20 mA

TEMPERATURE CARDS

- 6 temperature inputs PT100
- 6 temperature inputs PT1000



PORTS AND COMMUNICATION PROTOCOLS

- Ethernet
- Single-mode optical fibre - OPTOSM
- Multi-mode optical fibre - OPTOMM
- Plastic optical fibre - OPTOP
- RS485
- CANbus 2x
- USB 2.0
- WiFi*

* after agreement with the manufacturer

- Modbus RTU/TCP
- IEC 60870-5-103
- DNP 3.0
- Profibus
- CANbus/PPM 2
- IEC 61850



RECORDERS

- event recorder, 1000 events
- interference recorder up to 160 s sampling frequency 1.6 - 3.2 kHz
- criterion recorder for TRR 250 ms
- recording of instantaneous values, TrueRMS
- phasor

DIMENSIONS

e²TANGO-2000

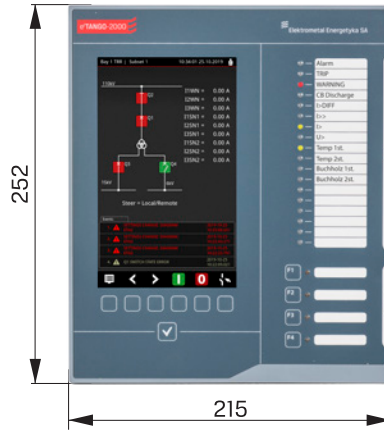

J10

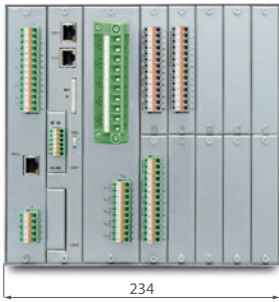

J14

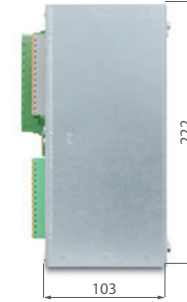
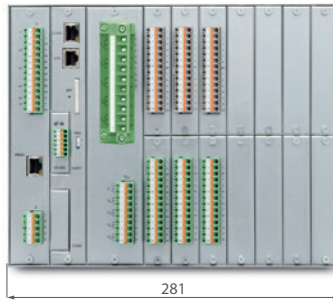

INSTALLATION METHODS

flush installation

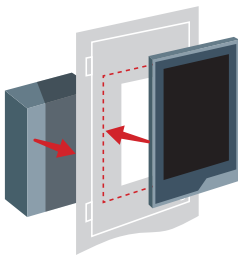

surface installation

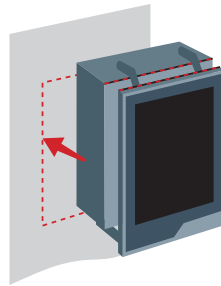

version 1

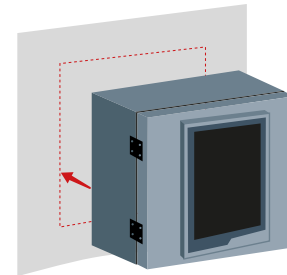

version 3

mixed installation

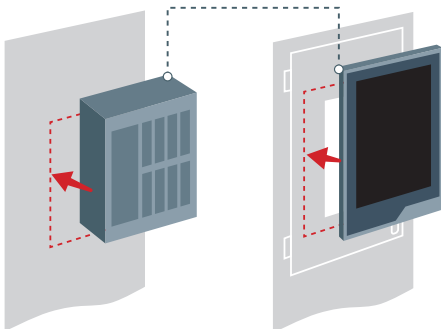

installation in a rack cabinet

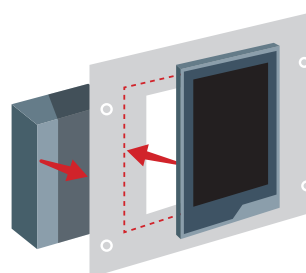

TECHNICAL PARAMETERS

Power supply with auxiliary voltage	
DC voltage	110 V, 220 V (80-300 V DC)
AC voltage	230 V (88-265 V AC)
Optional	24 V (19-58 V AC/DC)
Max. power consumption (panel and unit)	30 W (VA)
Current measurement circuits	
Rated current	1 A or 5 A
Rated frequency	50 Hz
Phase current measurement range	0.05-150 A
IO current measurement range	0.1-100 A
Voltage measurement circuits	
Rated voltage	57,7/100 V
Rated frequency	50 Hz
Voltage measurement range	3-120 V
Measurement accuracy	
I1, I2, I3 (0.1-150 A)	1%
U1, U2, U3, U0 (5-120 V)	1%
IO (0.1-100 A)	1%
P, Q, EC, EB (U>5 V, 0.1 A<I<10 A)	1%
f (U>5 V)	10 mHz
φ 1, φ 2, φ 3, φ 0 (U>5 V, 0.1 A<I<10 A)	1°
Protections parameters	
Transformer differential protection operate time	typically 27 ms
Overcurrent protections operate time	typically 35 ms
Reset ratio of overload protections	Configurable
Reset ratio of underload protections	Configurable
Parameters of W1, W2, W3 binary outputs (breaker control)	
Voltage on open contacts	250 V AC, 440 V DC
Circuit activation at 220 V DC	5.0 A
Circuit deactivation at 220 V DC (L/R = 40 ms)	0.3 A
Circuit deactivation at 220 V AC (cos φ = 0.4)	5 A (for PSUH1 card)
Circuit deactivation at 220 V AC (cos φ = 0.4)	2.0 A
Parameters of binary outputs (other)	
Voltage on open contacts	250 V AC, 440 V DC
Permanent load	5.0 A
Circuit deactivation at 220 V DC (L/R = 40 ms)	0.1 A
Circuit deactivation at 220 V AC (cos φ = 0.4)	5 A (for OUTH1 card)
Circuit deactivation at 220 V AC (cos φ = 0.4)	2.0 A
Parameters of binary inputs	
Rated voltage	110/230 V AC/DC
Optional	24 V (19-58 V AC/DC)
Other on request	
Maximum current consumption at 220 V DC; 230 V AC	2 mA; 15 mA
Environmental conditions	
Operating temperature	-10°C to +55°C
Storage temperature	-25°C to +70°C
Relative humidity	5% to 95%, without water vapour condensation
Vibrations and mechanical impacts	Class 1 acc. to IEC 60255-21
Electromagnetic interferences	Class B acc. to IEC 60255-26
Safety	
Insulation electric strength	2 kV/50 Hz/60 s acc. to IEC 60255-27
Dimensions	
Weight (central unit/operator panel)	5 kg/1 kg
Central unit dimensions (WxDxH mm)	222x103x187/234/281
Central unit protection class	IP 3X/IP 4X (option)
Panel protection class (front plate side)	IP 4X/IP 54 (option)

e²TANGO-STUDIO SOFTWARE

The e²TANGO-Studio is an engineering program dedicated to the e²TANGO bay controller and, at the same time, a configuration tool for the panel. The programme has been developed and equipped with a rich set of functionalities, which, combined with a clear visual configuration of widgets, becomes excellent support in everyday work, enabling the creation of projects for many devices, panels, switchboards, or stations.



advanced designing

possibility of preparing the devices' configuration for the whole switchboard on the PC and its distribution using USB

user elements

defining customised graphic elements of the synoptic diagram



quick configuration assistant

facilitating the first use of the programme and support during regular work



on-line preview

live preview of I/O statuses, measurements; real preview of the image displayed on the LCD screen

displaying compliance

preview of the actual view of the panel screen



possible further expansion using plug-ins

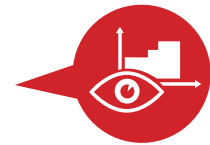

visual characteristics' shaping

graphical and standard configuration of protections' settings

prosta weryfikacja nastaw i selektywności

presentation of the whole overcurrent protections' family presentation on one chart

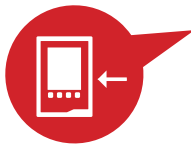

full statuses' view access to all internal statuses of the device and protections

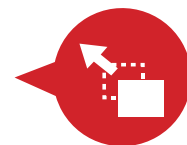

instant user screen designing

placement of elements supported by drag&drop method

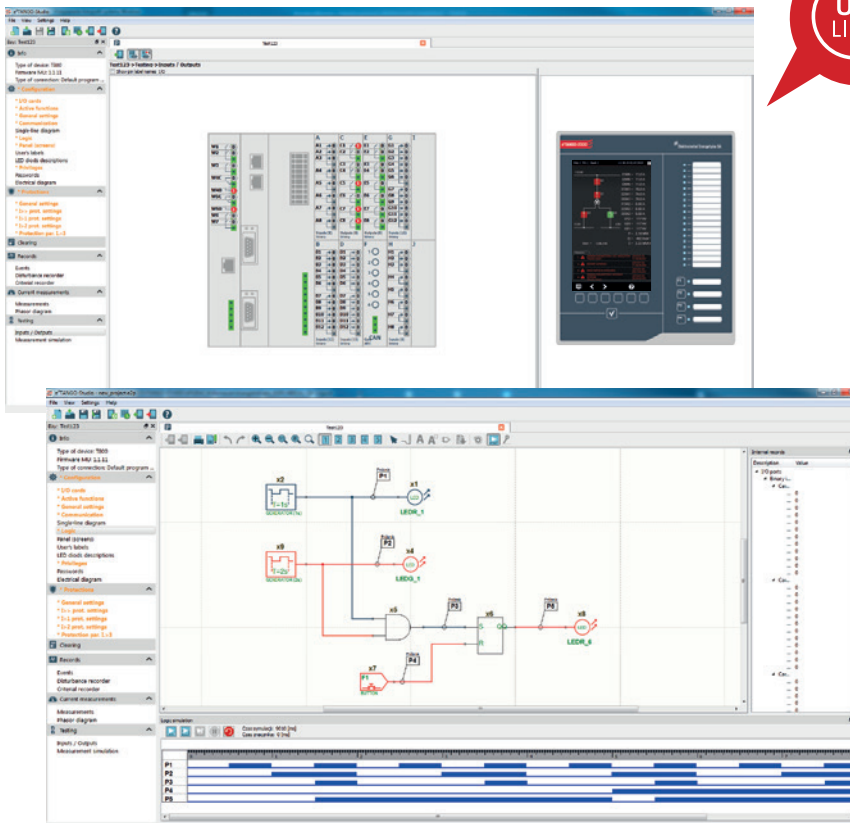

logic simulator

possibility of full simulation of logic without connecting to the device

logic legibility

possibility of dividing the logic into blocks and sheets

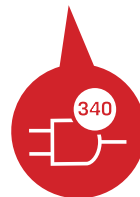

operation of extended logical dependencies

up to 340 logical gates/functors

ADVANCED LOGIC EDITOR AND SIMULATOR

The e²TANGO-Studio features an advanced and extended logic editor that allows for simulating the logic circuit, also visible from the panel, without connecting the device. It allows previewing logical statuses while working with the device, which facilitates project preparation, as well as commissioning and servicing of switching stations. It gives the possibility to design non-standard logics dedicated to the requirements of the client's infrastructure.

STANDARISATION

PN-EN 60255-1	Measuring relays and protection equipment. Part 1: Common requirements.
PN-EN 60255-26	Measuring relays and protection equipment. Part 26: Electromagnetic compatibility requirements.
PN-EN 60255-27	Measuring relays and protection equipment. Part 27: Product safety requirements.

CERTIFICATES AND AWARDS



IEC Certificate of Compliance
No. 005/2019

for the e²TANGO-2000 HV
protection units



Gold medal
ENERGETAB 2015 trade fair



Minister of Energy Cup
ENERGETAB 2018 trade fair



Mazovian Quality Award

ELEKTROMETAL ENERGETYKA SA QUALITY

Integrated Management System is implemented in the company, based on the following standards:

- PN-EN ISO 9001 Quality management systems
- PN-EN ISO 14001 Environmental management systems
- PN-EN ISO 45001 Occupational health and safety management systems

ORDER FORM

To order the e²TANGO-2000 protections, please fill in this part of the form according to the INSTRUCTIONS FOR FILLING IN THE FORM on the next page.

STEP 1

① panel version	<input checked="" type="checkbox"/> 2000-TRR ¹⁾				
② central unit version	<input checked="" type="checkbox"/> J10	<input type="checkbox"/> J14	<input type="checkbox"/> J10H ²⁾	<input type="checkbox"/> J14H ¹⁾	
③ TR measuring card version	<input checked="" type="checkbox"/> TR (standard, 5I+4U)				
④ measuring card parameters	<input checked="" type="checkbox"/> 5 A	<input type="checkbox"/> 1 A			
⑤ power supply voltage	<input checked="" type="checkbox"/> UNI (110/230 V AC/DC)	<input type="checkbox"/> 24V (24/48 V AC/DC)	<input type="checkbox"/> others		
Ethernet communication port (standard on each central unit)					
⑥ COM1	<input checked="" type="checkbox"/> x-none	<input type="checkbox"/> RS485	<input type="checkbox"/> CANx2	<input type="checkbox"/> OPTOMM	<input type="checkbox"/> OPTOP <input type="checkbox"/> Profibus <input type="checkbox"/> others
⑦ COM2	<input checked="" type="checkbox"/> x-none	<input type="checkbox"/> RS485	<input type="checkbox"/> CANx2	<input type="checkbox"/> OPTOMM	<input type="checkbox"/> OPTOSM <input type="checkbox"/> OPTOP <input type="checkbox"/> Profibus <input type="checkbox"/> others
⑧ installation method	<input checked="" type="checkbox"/> Z-flush	<input type="checkbox"/> N1 - surface ver. 1	<input type="checkbox"/> N3 - surface ver. 3	<input type="checkbox"/> M - Mixed	<input type="checkbox"/> ZR - flush in rack cabinet
⑨ panel-unit cable length	<input checked="" type="checkbox"/> S-1 m	<input type="checkbox"/> L-2 m	<input type="checkbox"/> other		
⑩ IP protection class	<input checked="" type="checkbox"/> IP 4X	<input type="checkbox"/> IP 54 ³⁾			
⑪ communication IEC 61850	<input checked="" type="checkbox"/> EX-none	<input type="checkbox"/> O-ETH fibre optic	<input type="checkbox"/> O2-ETH fibre optic with PRP	<input type="checkbox"/> O2G-O2+GOOSE	<input type="checkbox"/> E2-electric
	<input type="checkbox"/> E-ETH electric	<input type="checkbox"/> EG-ETH electric+GOOSE	<input type="checkbox"/> OG-ETH fibre optic +GOOSE	<input type="checkbox"/> E2G-electric +GOOSE	
⑫ language version	<input type="checkbox"/> PL	<input checked="" type="checkbox"/> EN	<input type="checkbox"/> other (in agreement with manufacturer)	

1) e²TANGO 2000-TRR requires using TRR expansion card. The TRR card is available for J10 and J14 units, the card simultaneously occupies two slots:

C and E (in case of two-winding transformer), the card simultaneously occupies four slots: C, E, D and F (in case of three-winding transformers)

2) reinforced W1, W2, W3 outputs

3) universal card for voltages between 24-48 V AC/DC

4) protection class IP 54 only available in version with flush and mixed installation

5) IEC 61850 communication is handled through additional communication connectors in the operator panel

STEP 2

		Slot													
		A	C	E	G	I	K	M	B	D	F	H	J	L	N
Card name	Kod														
CPU processor card	-	standard in every device													
PSU power supply card - 7 relay outputs	-	standard in every device													
Ethernet communication port	-														
current measurement for differential protection**	TRR			X											
8 binary inputs	8IN	<input checked="" type="checkbox"/>	<input type="checkbox"/>	<input type="checkbox"/>	<input type="checkbox"/>	<input type="checkbox"/>	<input type="checkbox"/>	<input type="checkbox"/>	<input type="checkbox"/>	<input type="checkbox"/>	<input type="checkbox"/>	<input type="checkbox"/>	<input type="checkbox"/>	<input type="checkbox"/>	<input type="checkbox"/>
12 binary inputs	12IN	standard in every device													
8 binary inputs 24-48 V*	8IN24	<input type="checkbox"/>	<input type="checkbox"/>	<input type="checkbox"/>	<input type="checkbox"/>	<input type="checkbox"/>	<input type="checkbox"/>	<input type="checkbox"/>	<input type="checkbox"/>	<input type="checkbox"/>	<input type="checkbox"/>	<input type="checkbox"/>	<input type="checkbox"/>	<input type="checkbox"/>	<input type="checkbox"/>
12 binary inputs 24-48 V*	12IN24	<input type="checkbox"/>	<input type="checkbox"/>	<input type="checkbox"/>	<input type="checkbox"/>	<input type="checkbox"/>	<input type="checkbox"/>	<input type="checkbox"/>	<input type="checkbox"/>	<input type="checkbox"/>	<input type="checkbox"/>	<input type="checkbox"/>	<input type="checkbox"/>	<input type="checkbox"/>	<input type="checkbox"/>
8 relay outputs	8OUT	<input type="checkbox"/>	<input checked="" type="checkbox"/>	<input type="checkbox"/>	<input type="checkbox"/>	<input type="checkbox"/>	<input type="checkbox"/>	<input type="checkbox"/>	<input type="checkbox"/>	<input type="checkbox"/>	<input type="checkbox"/>	<input type="checkbox"/>	<input type="checkbox"/>	<input type="checkbox"/>	<input type="checkbox"/>
4 relay outputs, reinforced	4OUTH	<input type="checkbox"/>	<input type="checkbox"/>	<input type="checkbox"/>	<input type="checkbox"/>	<input type="checkbox"/>	<input type="checkbox"/>	<input type="checkbox"/>	<input type="checkbox"/>	<input type="checkbox"/>	<input type="checkbox"/>	<input type="checkbox"/>	<input type="checkbox"/>	<input type="checkbox"/>	<input type="checkbox"/>
4 analogue inputs 0-10 V	AI10	<input type="checkbox"/>	<input type="checkbox"/>	<input type="checkbox"/>	<input type="checkbox"/>	<input type="checkbox"/>	<input type="checkbox"/>	<input type="checkbox"/>	<input type="checkbox"/>	<input type="checkbox"/>	<input type="checkbox"/>	<input type="checkbox"/>	<input type="checkbox"/>	<input type="checkbox"/>	<input type="checkbox"/>
4 analogue inputs 4-20 mA	AI20	<input type="checkbox"/>	<input type="checkbox"/>	<input type="checkbox"/>	<input type="checkbox"/>	<input type="checkbox"/>	<input type="checkbox"/>	<input type="checkbox"/>	<input type="checkbox"/>	<input type="checkbox"/>	<input type="checkbox"/>	<input type="checkbox"/>	<input type="checkbox"/>	<input type="checkbox"/>	<input type="checkbox"/>
4 analogue outputs 0-10 V	AO10	<input type="checkbox"/>	<input type="checkbox"/>	<input type="checkbox"/>	<input type="checkbox"/>	<input type="checkbox"/>	<input type="checkbox"/>	<input type="checkbox"/>	<input type="checkbox"/>	<input type="checkbox"/>	<input type="checkbox"/>	<input type="checkbox"/>	<input type="checkbox"/>	<input type="checkbox"/>	<input type="checkbox"/>
4 analogue outputs 4-20 mA	AO20	<input type="checkbox"/>	<input type="checkbox"/>	<input type="checkbox"/>	<input type="checkbox"/>	<input type="checkbox"/>	<input type="checkbox"/>	<input type="checkbox"/>	<input type="checkbox"/>	<input type="checkbox"/>	<input type="checkbox"/>	<input type="checkbox"/>	<input type="checkbox"/>	<input type="checkbox"/>	<input type="checkbox"/>
6 temperature inputs PT100	PT1	<input type="checkbox"/>	<input type="checkbox"/>	<input type="checkbox"/>	<input type="checkbox"/>	<input type="checkbox"/>	<input type="checkbox"/>	<input type="checkbox"/>	<input type="checkbox"/>	<input type="checkbox"/>	<input type="checkbox"/>	<input type="checkbox"/>	<input type="checkbox"/>	<input type="checkbox"/>	<input type="checkbox"/>
6 temperature inputs PT1000	PT10	<input type="checkbox"/>	<input type="checkbox"/>	<input type="checkbox"/>	<input type="checkbox"/>	<input type="checkbox"/>	<input type="checkbox"/>	<input type="checkbox"/>	<input type="checkbox"/>	<input type="checkbox"/>	<input type="checkbox"/>	<input type="checkbox"/>	<input type="checkbox"/>	<input type="checkbox"/>	<input type="checkbox"/>
		J10							J14						

* universal card for voltages between 24-48 V AC/DC

** the card placed in slots C and E (SN1) and D and F (SN2)

additional requirements:

STEP 3

Your code:

e²TANGO

①

②

③

④

⑤

⑥

⑦

⑧

⑨

⑩

⑪

⑫

A

B

C

D

E

F

G

H

I

J

K

L

M

N

INSTRUCTIONS FOR FILLING IN THE FORM

STEP 1

The presented table includes basic technical parameters of the e²TANGO-2000 protections. Only 1 item should be selected from each item numbered from 1 to 10. If "other" is selected, enter the ordered value in the corresponding field in STEP 3.

Explanation for step 1.

- - recommended basic configuration
- OPTOMM - multi-mode fibre op
- N1 - surface installation ver. 1
- N3 - surface installation ver. 3

STEP 2

The presented table includes a list of available expansion cards and possible places for their installation in the e²TANGO-2000 HV protection central unit. No tick box means that the given card cannot be installed in a given place. Select the cards to be ordered from the list and mark with the "X" slot in which they are to be installed. The cards' distribution should start with the A slot. The unit capacities are marked with a background colour in the table, respectively.

Explanation for step 2.

- - recommended basic configuration
- maximum 4 cards 8OUT
- maximum 1 AI10 card or 1 AI20 card
- maximum 1 AO10 card or 1 AO20 card
- maximum 1 PT1 card or 1 PT10 card
- the TRR card can be installed only in slot C and E (SN1) or D and F (SN2) in J10 and J14 units

Describe additional requirements in the designated area.

View of the central unit with a selection of the slot arrangement for expansion cards

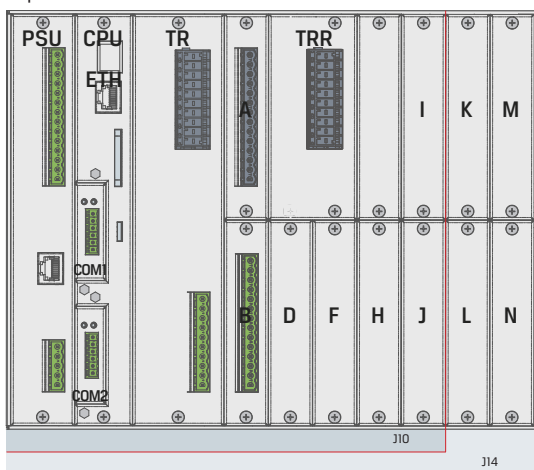

STEP 3

controller should be completed in appropriate fields. The e²TANGO-2000 code created in such a way together with other requirements or a scanned page of the form should be sent with the order to: export@elektrometal-energetyka.pl

Example of the e²TANGO-2000 HV protection configuration:

① e ² TANGO-2000-TRR	⑩ protection class IP 4X IEC 61850
② J10 central unit	⑪ communication (electric)
③ TR measuring card	⑫ EN
④ rated current of the measuring card 5 A	A slot A: card 8IN
⑤ universal binary inputs voltage	B slot B: card 8OUT
⑥ OPTOMM	C slot C: X
⑦ RS485	D slot D: X
⑧ mixed installation	E slot C+E: TRR card
⑨ 8 m cable	F slot D+F: TRR card

Example of correct code completion:

e ² TANGO	2000-TRR	J10	TR	5A	UNI	OPTOMM	RS485	M	8	IP4X	E	EN
8IN	8OUT	X	X	TRR	TRR							

ELEKTROMETAL ENERGETYKA SA

67 Działkowa Street

02-234 Warsaw

tel. (+48) 22 350 75 50

fax (+48) 22 350 75 51

eaz@elektrometal-energetyka.pl

www.elektrometal-energetyka.pl